

# Installation Instructions

---

## RDH 6000 Recessed Over Door Heater

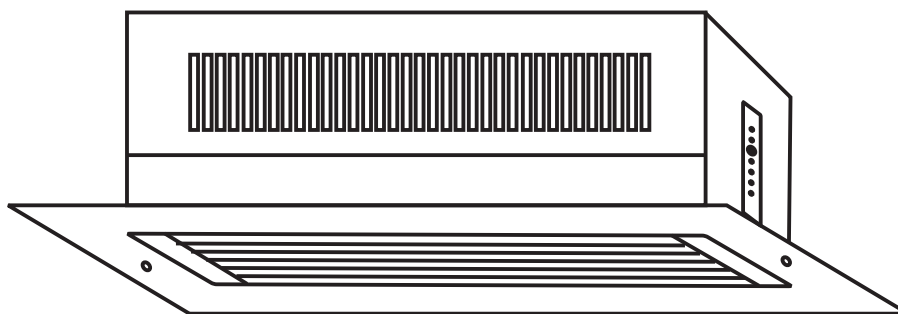

Complete with **REMOTE SWITCH UNIT**  
for Fan only, 3kW and 6kW

Please retain for future reference



Commercial Electric Heat Limited  
Unit 712  
Thorp Arch Trading Estate  
WETHERBY  
West Yorkshire  
LS23 7BJ

Tel 01937 844994 Fax 01937 844123  
email [sales@cehltd.co.uk](mailto:sales@cehltd.co.uk)  
web [www.cehltd.co.uk](http://www.cehltd.co.uk)

---

## CONTENTS

Remove from carton and check contents ;

- heater unit
- grille frame and 2 no roundhead woodscrews
- 2 no support brackets, 4 no. machine screws and 4 no woodscrews
- ODH-RSW three switch control unit
- 25mm cord grip bush and locknut

## LOCATION

The heater must be installed at least 2.0m above floor level. All round minimum clearance dimensions must be observed.

**The heater is designed to take input air from the ceiling void it is therefore imperative that a suitably sized inlet grille is provided within the ceiling or enclosure.**

**The heater must not be covered or the airflow impeded in any way.**

**If one inlet grille is at its minimum dimension the other must have an unrestricted airflow**

For optimum effect the heater should be mounted as close as possible to the top of the doorway. The maximum recommended mounting height is 2.3m for 3kW and 2.8m for 4.5, 6.0 and 9.0kW units.

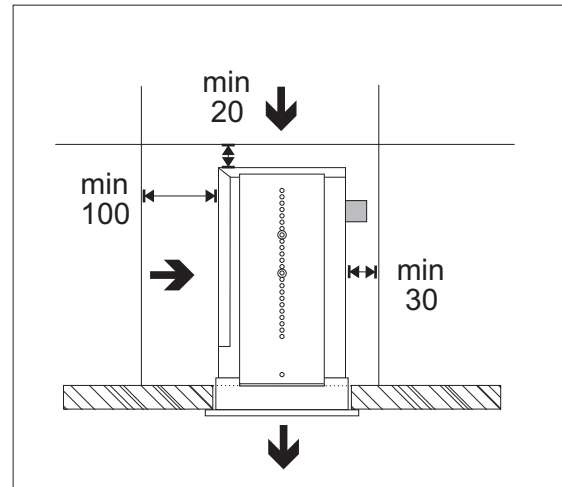

## CONTROL

### Remote Switch

The Remote Switch Unit allows ON/OFF, Fan only with 3kW and 6kW.

### Thermostat (CRST)

If a thermostat is required remove link between L and Lt and replace with connection to thermostat. A thermostat with at least a 3A rating is required. This will switch the heater off when set temperature is reached. To allow the fan only to operate in summer the thermostat must be set high and the heat switches must be in the off position.

## ELECTRICAL CONNECTION

The heater should be installed in accordance with the latest edition of the IEE Requirements for Electrical Installation (BS 7671:2001)

The unit should be permanently connected to a suitable 230Vac power supply incorporating a means of isolation having a contact separation of at least 3mm in all poles.

Remove heater cover, position heater in ceiling (See Fixing). Fix remote switch unit in suitable location.

Select cabling with 4 cores and earth and of appropriate size for current and volt drop.

Pass cable/s through cord grip in back of unit. Leave sufficient length for connection but ensuring cables do not foul blower unit. Make off connections to connector block and earth stud in accordance with circuit diagram RDH-W-003 (copy on back page )

If remote switching is not required connect power supply to L and N and link Lt,Lsw,LI and LII with 1.5sqmm cable.

**Note: Ensure link between L and Lt is secure otherwise heater will not operate**

Tighten up cord grip. Replace cover.

**IMPORTANT : always check to ensure the heating elements cannot be energised without the fan**

### OVER TEMPERATURE CUT OUT

Should the heater exceed normal operating temperature the over temperature cut out on the heating elements will operate switching off both elements and fans.

**To RESET** - switch off power to the unit and allow to cool before switching on again. If the problem persists consult a suitably qualified person.



---

## FIXING

This unit is designed for installation in a plasterboard or similar ceiling where a free height above the surface of the ceiling is at least 230mm.

### Fitting in plasterboard type ceiling or bulkhead

A 810mm x 130mm hole should be made in the ceiling and suitably framed.

Fix support brackets, with machine screws provided to screwed inserts in side of unit

The unit can be fixed in two ways depending on access available (Note future access will be required for servicing) .

1) Locate the brackets flush with the front of the heater. Place unit in ceiling from below and secure brackets with woodscrews provided.(see Fig 1). Ensure sufficient space is left to allow the insertion of the grille frame between heater and bracket. This option may require electrical connection prior to positioning..The grille frame is then positioned and fixed with the 2 round headed screws provided.

2) Locate the brackets to sit on top of the support frame (see Fig 2).Position the grille frame in the opening and loosely fix with the 2 round headed screws provided. Place unit in ceiling from above and position within grille frame. Secure brackets with woodscrews provided, tighten grille frame fixing screws.

### Fitting in modular ceiling.

The heater can be fitted in a modular ceiling but drop rod fixing (see below) will be required. The ceiling tile is cut back as appropriate and finished either with the grille frame or additional T bar section.

### Drop rod fixing

Additional fixings may be required if the ceiling construction is not strong enough to take the heater weight. Two 8mm holes are provided in the top of the heater to allow the fixing of drop rods (by others).

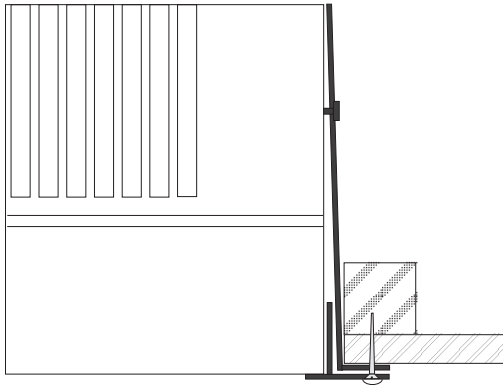

Fig 1

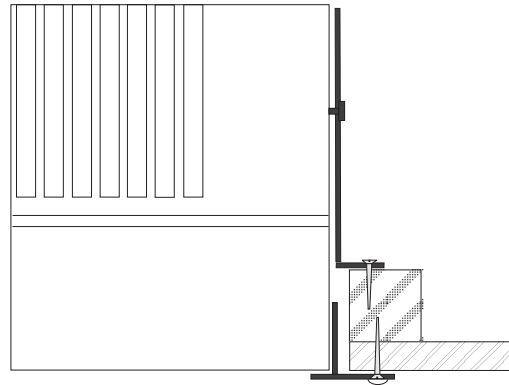

Fig 2

## MAINTENANCE

Isolate the heater and remove any build up of dust etc. every 6 months. Check that the heater has not been covered or the airflow restricted in any way.



Commercial Electric Heat Limited  
Wetherby LS23 7BJ

No	Part No	Description
1	B078-01	Heating element
2	D001-01	Fan motor
3	F047	Connector block
4	C014	Blower unit
5	ODH-RSW	Remote switch unit
6	E113	Relay
7		O T cut out

No	Revision	Date
1	Add external cut outs/tstat	08/04

Title **RDH-6000 6.0kW  
Recessed Over Door  
Heater**

Drawn by	NEB	Date	06.09.00
Scale		Drawing No.	RDH-W-003
nts		Rev	1

**Remote Switch ODH-RSW**

**IMPORTANT:**  
Any modification to the switching in this circuit must ensure that the heating elements cannot be energised without the fan running.

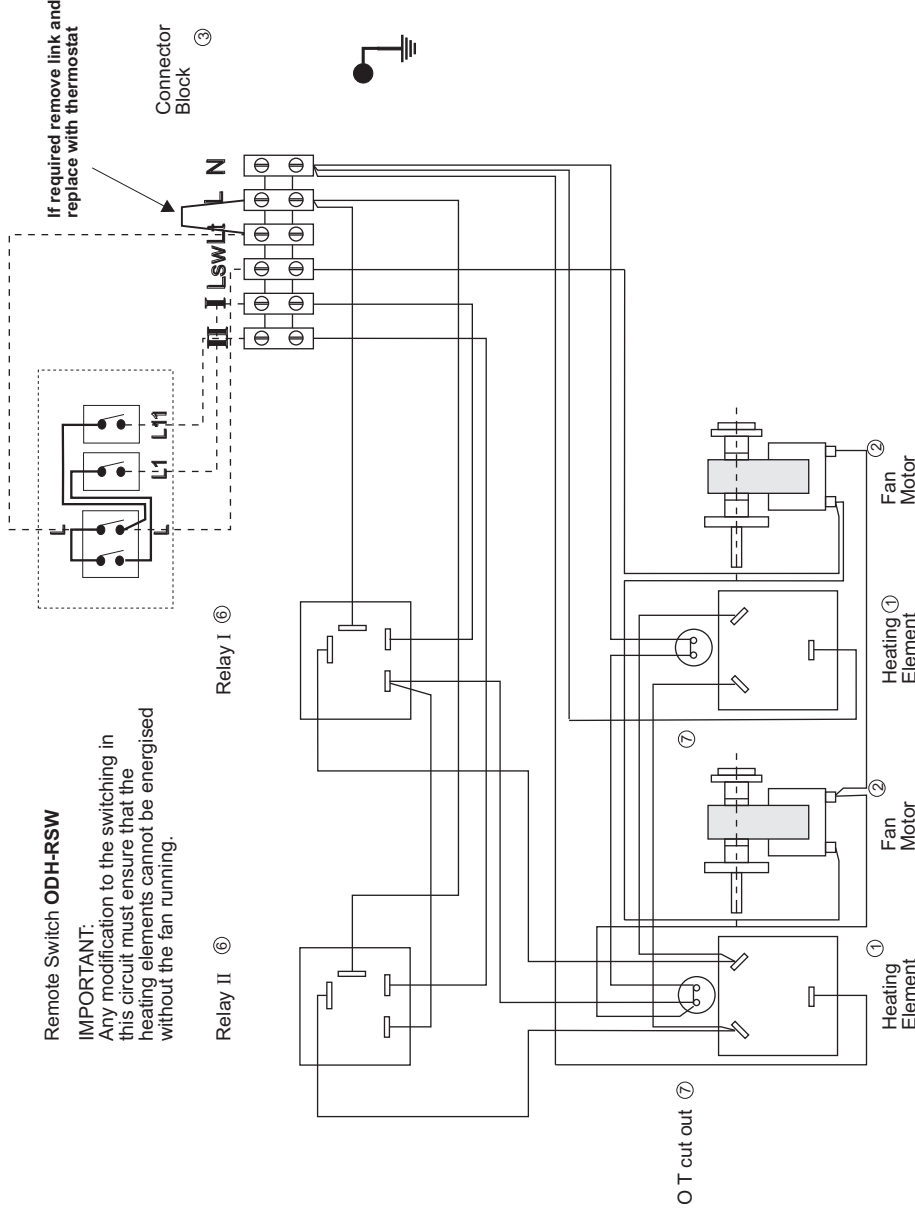

**Schematic diagram**

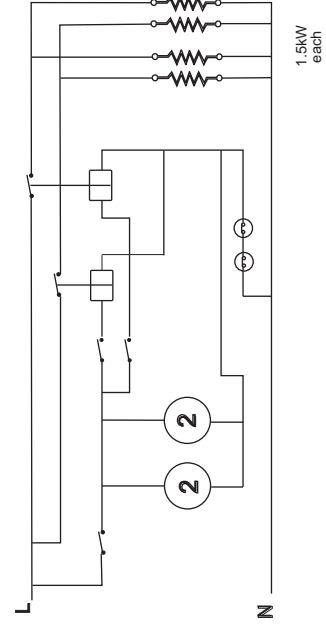

To reset over temperature cut out(s)  
Switch off, check for cause of overheating and rectify,  
allow to cool (5 minutes) then restore supply  
Heater does not function again until power  
has been removed from cut out.  
All wiring in 105°C Trirated Panel wire