

Installation Instructions CCB Kickspace Heater

Reference
J060b

- Remove from carton and check contents :-
- grille and fixing screws (2)
 - heater assembly
 - thermostat knob (if specified)

CAUTION

DO NOT mount heater where obstruction of the heater airflow might occur.

HEATER LOCATION

The heater is for mounting into a deep recess on a vertical surface such as below kitchen units or shop fittings. Do NOT install under heavily used work area where air discharge temperature may be uncomfortable. Floor material should be checked before heater installation to be sure it will not discolour or distort at temperatures around 60 deg.C

The unit can also be used in a vertical position but only with upward discharge.

INSTALLATION

- 1) Create cut-out 568mm x 92mm in wall ensuring at least a depth of 295mm from the front face and adequate fixing/support locations are available. The unit must not be below the finished floor level.
- 2) Remove grille and screws holding heater cover, remove cover. Remove appropriate knock out. Pull through sufficient cable to make connections.
- 3) Make connections to terminal block and earth screw. The unit is supplied for 240Vac operation.
- 4) Replace cover and screws.
- 5) Push heater into opening, replace grille and attach unit to surface with two screws provided.

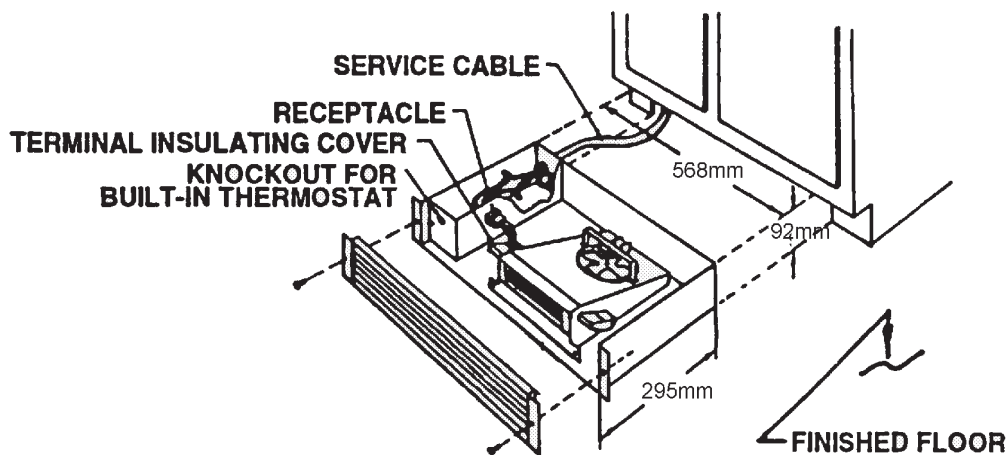

ELECTRICAL CONNECTIONS.

The Heater should be installed in accordance with the latest edition of the IEE Requirements for Electrical Installation (BS 7671:2001) by a suitably qualified person. The unit should be connected to a suitable 230Vac 50Hz.power supply incorporating a means of isolation having a contact separation of at least 3mm in all poles.

Connect as follows:-

- Green-yellow wire to terminal marked E , with earth symbol 
- Blue wire to terminal marked N
- Brown wire to terminal marked L

WARNING: THE HEATER MUST BE EARTHED.



OVER TEMPERATURE SAFETY CUT OUT.

The heater is fitted with a **MANUAL** reset thermal safety cutout to prevent overheating should the heater grille become accidentally blocked.

TO RESET

Disconnect from power supply. Determine cause of overheating and rectify. To reset insert small blade screwdriver or equivalent through grille into vertical slot located on lower centre of heater chassis and lift up.

THERMOSTAT OPERATION (if fitted)

Turn thermostat fully clockwise. Allow heater to run until room is at desired temperature.
 NOTE: Heater must run for approx. 5 minutes before thermostat will control at desired comfort level.
 Turn thermostat counterclockwise until heater just turns off.

MAINTENANCE

The unit should be cleaned every year to reduce build up of dust. To clean disconnect from power supply, remove grille and front screws, unplug unit and slide out. After cleaning, replace and all screws to maintain good ground continuity. Replace grille.

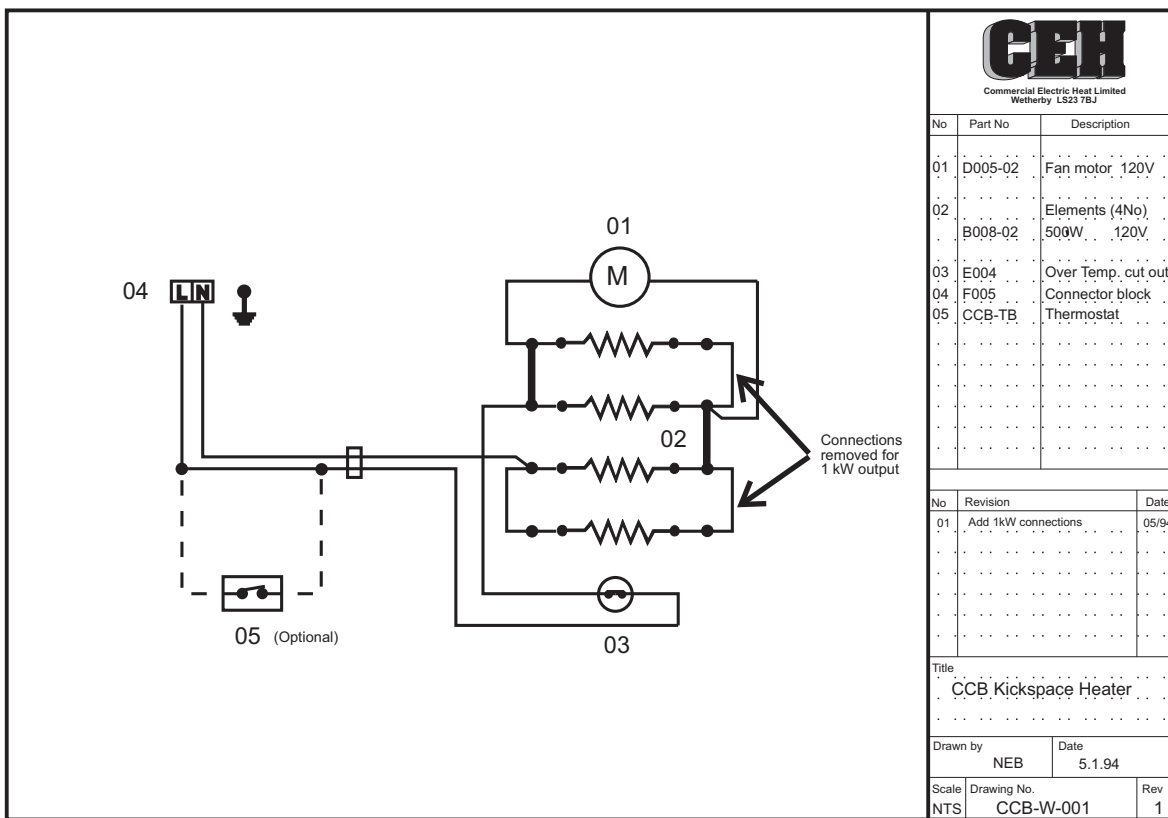

WARRANTY

This product is guaranteed, in accordance with our Conditions of Sale, for a period of 12 months from date of purchase. We will repair or replace, at our discretion, any part found to be defective. We cannot accept responsibility for any consequential liability.
 The warranty will be invalid if the heater has not been installed in accordance with these instructions.
 This does not affect your statutory rights.

Please keep these instructions for future reference.

The manufacturers reserve the right to change the specification at any time without prior notice E&OE

P01



Commercial Electric Heat Limited
 Unit 712
 Thorp Arch Trading Estate
 WETHERBY
 West Yorkshire
 LS23 7BJ

Tel 01937 844994 Fax 01937 844123
 Email sales@cehltd.co.uk Web www.cehltd.co.uk