

Installation Instructions

The RCHB-3210-TT Ceiling heater for surface mounting

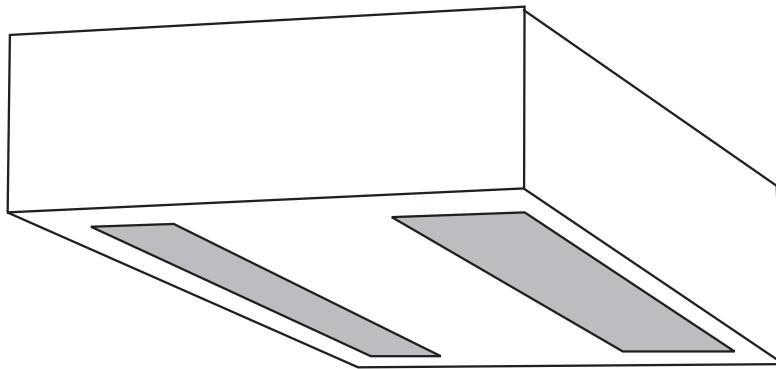

*with **integral relays** to allow connections
of Time clock and thermostat*

Please retain for future reference



Commercial Electric Heat Limited
Unit 712
Thorp Arch Trading Estate
WETHERBY
West Yorkshire
LS23 7BJ

Tel 01937 844994 Fax 01937 844123
Email sales@ceh ltd.co.uk Web www.ceh ltd.co.uk

SAFETY

The correct procedures for working at height must be adopted when installing this heater.

The heater must be installed by a suitably qualified person in accordance with current regulations.

CONTENTS

Remove from carton and check contents ;

- heater unit
- (Time clock and thermostat not supplied)

LOCATION

The heater must be installed at a minimum of 2 m and a maximum of 3m from the floor.

The heater can be positioned in the corner of a ceiling but for better heat distribution at least 600mm from each wall is preferable.

The unit should not be positioned over desks, counters or high level display racking wherever a constant flow of heated air may be uncomfortable or cause overheating of equipment.

CONTROL

FAN OUTPUT

The main relay (Terminals T1 and T2) controls the supply to the unit. This has to be switched by a fused 230V supply connection unit incorporating either a time switch / programmer for automatic control (CTTF) or an on/off switch for manual control. The fan runs continuously when the relay is switched on.

HEAT OUTPUT

The second relay controls the switching of the heating elements, they are not switched individually.

TEMPERATURE

The second relay (Terminals T3 and T4) is also switched by a fused 230V supply, usually the time controlled circuit. A single thermostat (CRST-16) can control all the heaters. Alternatively several can be used to create zones thus compensating for uneven heat requirements.

The thermostats should be mounted out of the direct influence of the heated airflow.

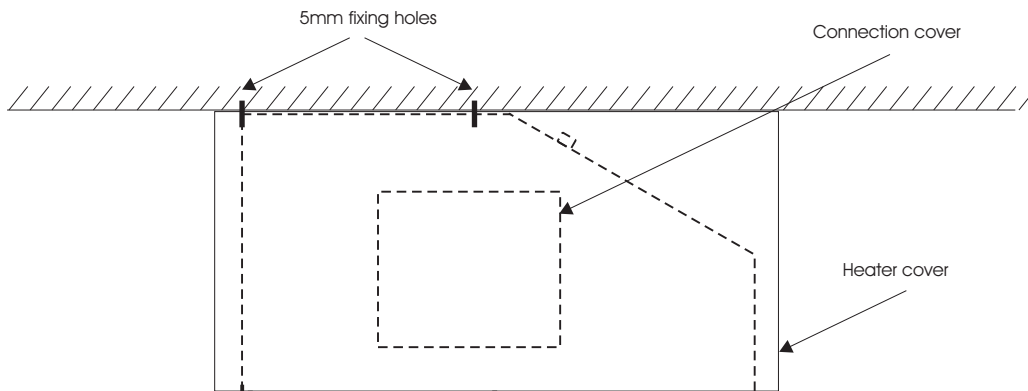

FIXING

This heater is designed for surface installation to any ceiling that can adequately support the unit. The unit weighs 9kgs.

Remove the front cover of the unit

Fixings are made through the top flat section of the heater body using the 4 No 5mm holes provided. This section must be flat on the ceiling as the edges of the cover are designed to fit against the ceiling.

Securely fix the heater and make off the electrical connections taking into account the routing of cables in relation to the cover. Ensure fixings and cables are clear of moving parts and the heater elements.

Re fix the cover ensuring the fan outlet is adjacent to the smaller outlet grille.

ELECTRICAL CONNECTION

The heater should be installed in accordance with the latest edition of the IEE Requirements for Electrical Installation (BS 7671:2001)

Remove tile adjacent to connection cover plate. Remove non captive screw from side connection cover and swivel to side. Position heater in ceiling (See Fixing)

A means of disconnection having a contact separation of 3mm in all poles should be incorporated in the power supply.

Select power cabling of appropriate size for current and volt drop for the heater.

Select control cabling with 4 cores and earth of appropriate size for current and volt drop

(Control/motor circuit power consumption approx 50W per unit)

Pass cable/s through cord grip in top of unit. Leave sufficient length for connection but ensuring cables do not foul blower unit. Make off connections to connector block and earth stud in accordance with circuit diagram RCH-W-012 (copy on back page and on top of unit)

Tighten up cord grip. Replace connection cover plate. Replace heater cover.

IMPORTANT : always check to ensure the heating elements cannot be energised without the fan running.

WARNING THE HEATER MUST BE EARTHED

OVER TEMPERATURE CUT OUT

Should the heater exceed normal operating temperature the over temperature cut out on the heating elements will operate. The fan will continue to run.

To RESET - switch off power to the unit and allow to cool before switching on again. If the problem persists consult a suitably qualified person.

MAINTENANCE

Isolate the heater and remove any build up of dust etc. every 6 months. Check that the heater has not been covered or the airflow restricted in any way.

WARRANTY

This product is guaranteed, in accordance with our Conditions of Sale, for a period of 12 months from date of purchase. We will repair or replace, at our discretion, any part found to be defective. We cannot accept responsibility for any consequential liability.

The warranty will be invalid if the heater has not been installed in accordance with these instructions.

This does not affect your statutory rights.

Warning
Multiple supply isolate ALL before opening connection cover.

Relay coil 1 to be energised by 230V from timer on/off controlled and fused supply
Relay coil 2 to be energised by 230V from thermostat controlled and fused supply

Heating element incorporates over temperature cut out .
Fan continues to run if cut out operates.

To reset:
Switch off and allow to cool (5 minutes) then restore supply

Heater does not function again until power has been removed from cut out.

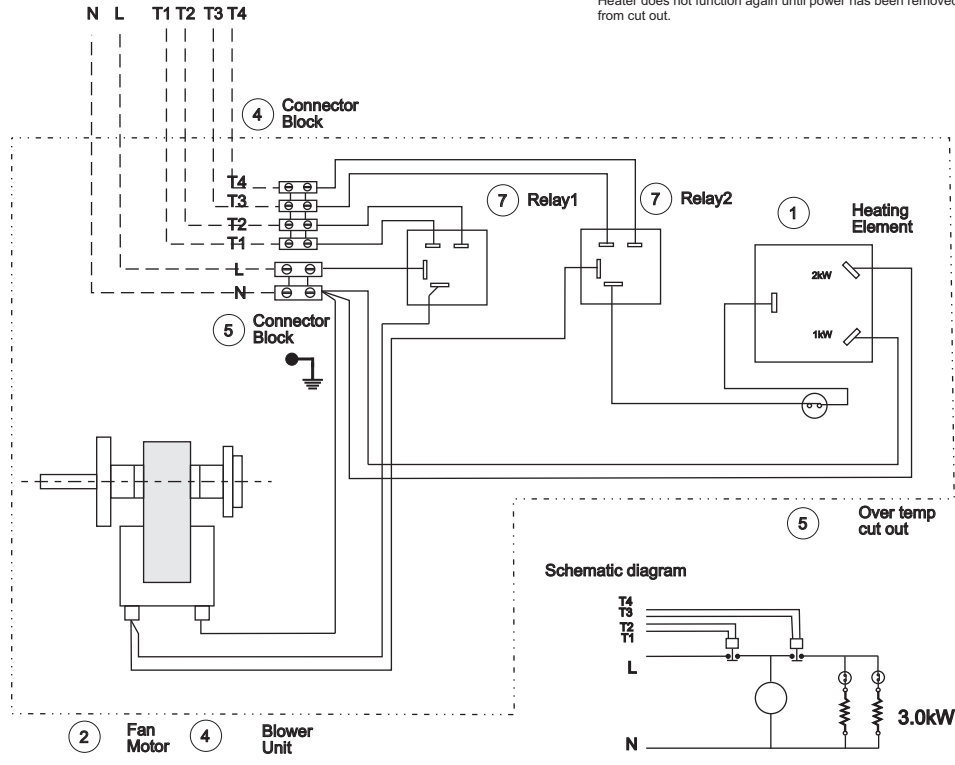

Commercial Electric Heat Limited
Wetherby LS23 7BJ

No	Part No	Description
1	B081-01	Heating element
2	D001-01	Fan motor
3	C001	Blower unit
4	F003	16A Con block
5	F040	40A Con block
6		Over temp cut outs
7	E113	Relay

No	Revision	Date
1		
2		

Title: **RCHS/R/B-3210-TT
Recessed Ceiling Htr
with integral relays**

Drawn by: **NEB** Date: **30.08.07**

Scale: **nts** Drawing No: **RCH-W-012** Rev: **0**

L011

One relay is connected in the incoming live to control the on and off of the heater. A second relay is connected between the first relay and the elements to control the heating elements only.

The fan motor will run continuously when there is power to the heater through relay 1

Each relay is independently switched via a fused power supply controlled by time clock or thermostat

See RCH-W-012 and RCH-W-013 for heater circuit detail

Note: Multiple supply isolate ALL before opening connection cover.

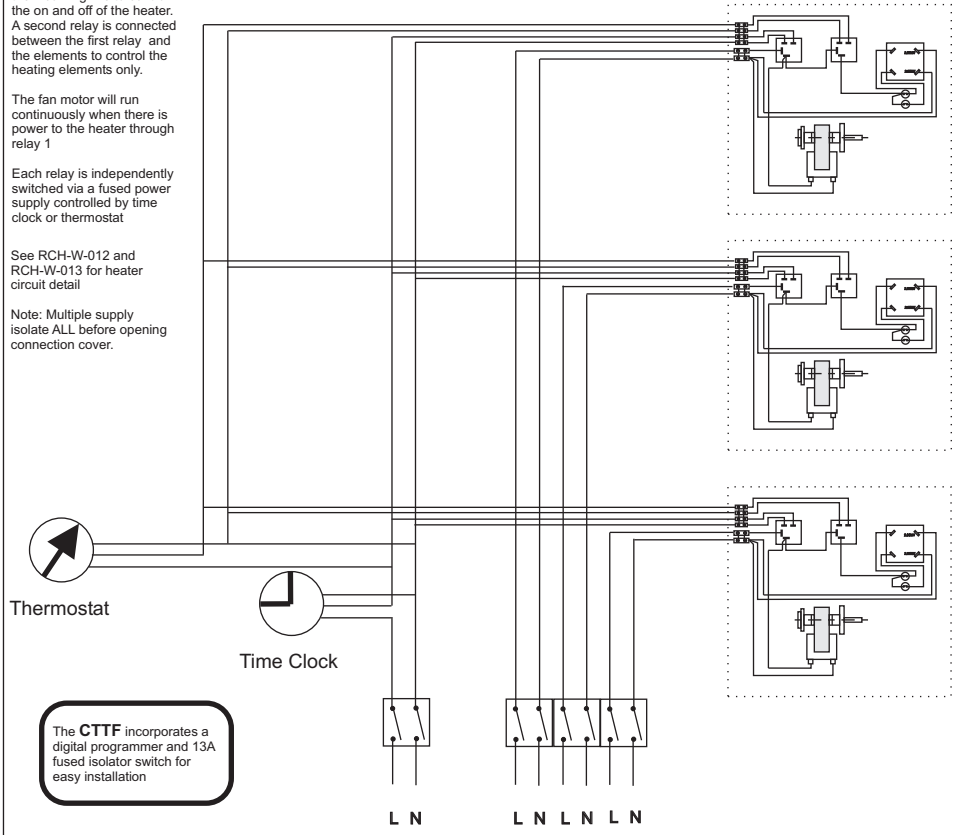

Commercial Electric Heat Limited
Wetherby LS23 7BJ

No	Part No	Description
1		
2		
3		
4		
5		
6		
7		

No	Revision	Date
1		
2		

Title: **Typical site connection
RCHX-xxxx TT
Recessed Ceiling Htr**

Drawn by: **NEB** Date: **30.08.07**

Scale: **nts** Drawing No: **RCH-W-014** Rev: **0**

L011