

# Installation Instructions

---

## RDH 9000 Recessed Over Door Heater

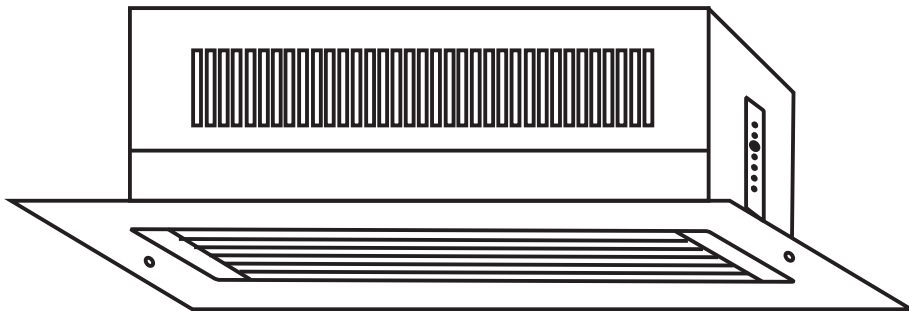

Complete with **REMOTE SWITCH UNIT**  
for Fan only, 4.5kW and 9kW

Please retain for future reference

---



Commercial Electric Heat Limited  
Burnfoot Industrial Estate  
HAWICK  
Roxburghshire  
TD9 8SL

Tel 01450 372103 Fax 01450 377800  
Email [sales@ceh ltd.co.uk](mailto:sales@ceh ltd.co.uk) Web [www.ceh ltd.co.uk](http://www.ceh ltd.co.uk)

---

## SAFETY

The correct procedures for working at height must be adopted when installing this heater.

The heater must be installed by a suitably qualified person in accordance with current regulations.

## CONTENTS

Remove from carton and check contents ;

- heater unit
- grille frame and 2 no roundhead woodscrews
- 2 no support brackets, 4 no. machine screws and 4 no woodscrews
- ODH-RSW three switch control unit
- 2 no 25mm cord grip bush and locknut

## LOCATION

The heater must be installed at least 2.0m above floor level. All round minimum clearance dimensions must be observed.

**The heater is designed to take input air from the ceiling void it is therefore imperative that a suitably sized inlet grille is provided within the ceiling or enclosure.**

**The heater must not be covered or the airflow impeded in any way.**

**If one inlet grille is at its minimum dimension the other must have an unrestricted airflow**

For optimum effect the heater should be mounted as close as possible to the top of the doorway. The maximum recommended mounting height is 2.3m for 3kW and 2.8m for 4.5, 6.0 and 9.0kW units.

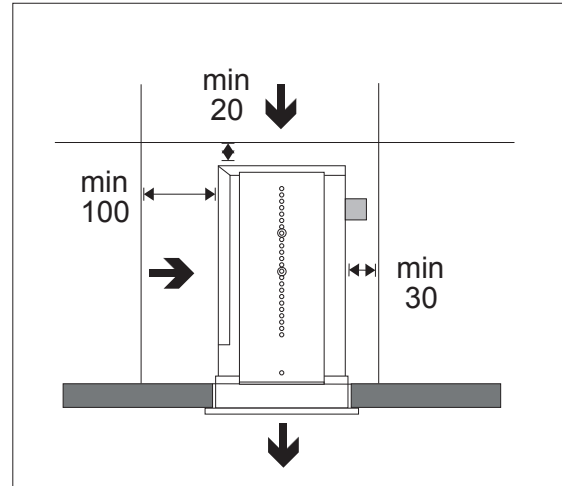

## CONTROL

### Remote Switch

The Remote Switch Unit allows ON/OFF, Fan only with 4.5kW and 9kW.

### Thermostat (CRST16 or CPRST)

If a thermostat is required remove link between Fuse and Lt and replace with connection to thermostat. A thermostat with at least a 3A rating is required. This will switch the heater off when set temperature is reached. To allow the fan only to operate in summer the thermostat must be set high and the heat switches must be in the off position.

The control circuit is fitted with a 3A fuse should this blow check for reason and replace , if the problem persists consult a suitably qualified person.

## ELECTRICAL CONNECTION

The heater should be installed in accordance with the latest edition of the IEE Requirements for Electrical Installation (BS 7671:2001)

The unit should be permanently connected to a suitable 400V ac 3 phase and neutral power supply incorporating a means of isolation having a contact separation of at least 3mm in all poles. For single phase connection connect L1,L2 and L3 together with 2.5sqmm cable and connect supply to L2 and N.

Remove heater cover, position heater in ceiling (See Fixing). Fix remote switch unit in suitable location. Select cabling with 4 cores and earth and of appropriate size for current and volt drop.

Pass cable/s through cord grip/s in back of unit. Leave sufficient length for connection but ensuring cables do not foul blower unit. Make off connections to connector block and earth stud in accordance with circuit diagram RDH-W-004 (copy on back page )

If remote switching is not required connect power supply to L and N and link L,LI and LII with 2.5sqmm cable.

**Note: Ensure link between Fuse and Lt is secure otherwise heater will not operate**

Tighten up cord grip. Replace cover.

**IMPORTANT : always check to ensure the heating elements cannot be energised without the fan running.**

### WARNING THE HEATER MUST BE EARTHED

### OVER TEMPERATURE CUT OUT

Should the heater exceed normal operating temperature the over temperature cut out on the heating elements will operate.

**To RESET** - switch off power to the unit and allow to cool before switching on again. If the problem persists consult a suitably qualified person.

---



---

## FIXING

This unit is designed for installation in a plasterboard or similar ceiling where a free height above the surface of the ceiling is at least 230mm. It is also sized to fit within a standard 1200mm x 600mm modular ceiling system.

### Fitting in plasterboard type ceiling or bulkhead

A 1180mm x 130mm hole should be made in the ceiling and suitably framed.

Fix support brackets, with machine screws provided to screwed inserts in side of unit

The unit can be fixed in two ways depending on access available. (Note future access will be required for servicing)

1) Locate the brackets flush with the front of the heater. Place unit in ceiling from below and secure brackets with woodscrews provided. (see Fig 1). Ensure sufficient space is left to allow the insertion of the grille frame between heater and bracket. This option may require electrical connection prior to positioning. The grille frame is then positioned and fixed with the 2 round headed screws provided.

2) Locate the brackets to sit on top of the support frame (see Fig 2). Position the grille frame in the opening and loosely fix with the 2 round headed screws provided. Place unit in ceiling from above and position within grille frame. Secure brackets with woodscrews provided, tighten grille frame fixing screws.

### Fitting in modular ceiling.

The unit weighs 16kgs and as such it is preferable that the heater is mounted using drop rods as detailed below. The ceiling tile should be cut back as appropriate and finished either with the grille frame or an additional T bar section.

### Drop rod fixing

Additional fixings may be required if the ceiling construction is not strong enough to take the heater weight. Two 8mm holes are provided in the top of the heater to allow the fixing of drop rods (by others).

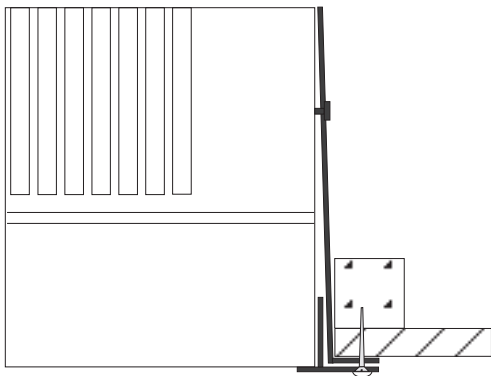

Fig 1

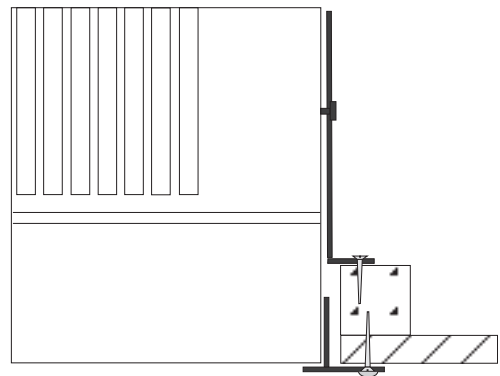

Fig 2

## MAINTENANCE

Isolate the heater and remove any build up of dust etc. every 6 months. Check that the heater has not been covered or the airflow restricted in any way.

## WARRANTY

This product is guaranteed, in accordance with our Conditions of Sale, for a period of 12 months from date of purchase. We will repair or replace, at our discretion, any part found to be defective. We cannot accept responsibility for any consequential liability.

The warranty will be invalid if the heater has not been installed in accordance with these instructions.

The manufacturers reserve the right to change the specification at any time without prior notice EO&E

---



Commercial Electric Heat Limited  
HAWICK TD8 8SL

No	Part No	Description
1	B078-01	Heating element
2	D001-01	Fan motor
3	F041	Connector block
4	C014	Blower unit
6	E075	Relay
7	ODH-RSW	Remote Switch unit
8		O T Cut out
9	F057	Fused Conn block
	E127	3A QB Fuse

No	Revision	Date
1	Add external cut outs/tstat	08/04
2	Add control fuse	08/07

Title		RDH-9000 9.0kW Over Door Heater	
Drawn by	NEB	Date	06.09.00
Scale	nts	Drawing No.	RDH-W-004
		Rev	2

