

# Installation Instructions

---

The RCHS-3210-TT for Modular T bar Ceilings

The RCHR-3210-TT for Plasterboard Ceilings

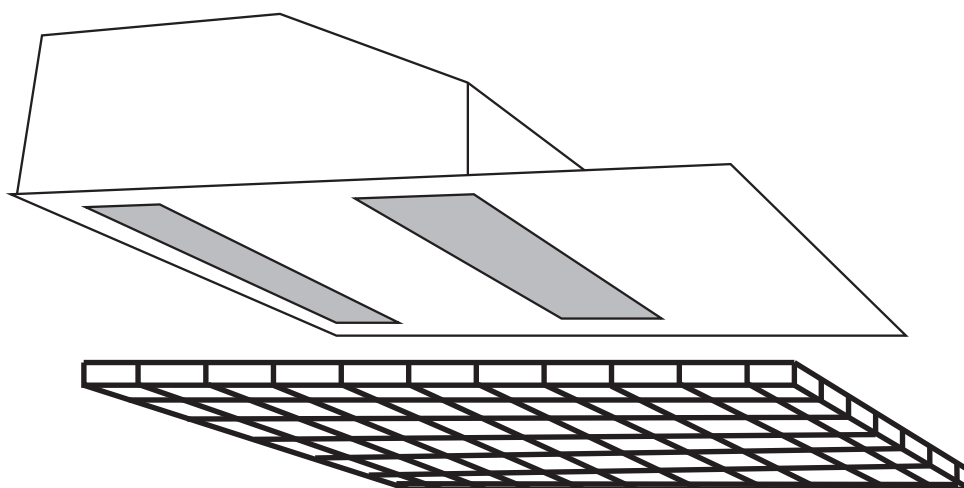

*with integral relays to allow connections  
of Time clock and Thermostat*

Please retain for future reference



Commercial Electric Heat Limited  
Burnfoot Industrial Estate  
HAWICK  
Roxburghshire  
TD9 8SL

Tel 01450 372103 Fax 01450 377800  
Email sales@cehltd.co.uk Web www.cehltd.co.uk

---

## SAFETY

The correct procedures for working at height must be adopted when installing this heater.  
The heater must be installed by a suitably qualified person in accordance with current regulations.

## CONTENTS

Remove from carton and check contents ;

RCHS-3210-TT

- heater unit
- support clips and 4 no. machine screws
- grille
- 25mm cord grip bush

RCHR-3210-TT

- heater unit
- support clips, 4 no. machine screws and 4 no. woodscrews
- framed grille and 6 no roundhead woodscrews
- 25mm cord grip bush

(Time clock and thermostat not included)

## LOCATION

The heater must be installed at a minimum of 2 m and a maximum of 3m from the floor.  
The heater can be positioned in the corner tile of a ceiling but for better heat distribution one tile (600mm ) from each wall is preferable. The unit should not be positioned over desks, counters or high level display racking wherever a constant flow of heated air may be uncomfortable or cause overheating of equipment.

## CONTROL

### FAN OUTPUT

The main relay (Terminals T1 and T2) controls the supply to the unit.. This has to be switched by a fused 230V supply connection unit incorporating either a time switch / programmer for automatic control (CTTF) or an on/off switch for manual control. The fan runs continuously when the relay is switched on.

### HEAT OUTPUT

The second relay controls the switching of the heating elements, they are not switched individually.

### TEMPERATURE

The second relay (Terminals T3 and T4) is also switched by a fused 230V supply, usually the time controlled circuit. A single thermostat (CRST-16) can control all the heaters. Alternatively several can be used to create zones thus compensating for uneven heat requirements.

The thermostats should be mounted out of the direct influence of the heated airflow.

## ELECTRICAL CONNECTION

The heater should be installed in accordance with the latest edition of the IEE Requirements for Electrical Installation (BS 7671:2001)

Remove tile adjacent to connection cover plate. Remove non captive screw from side connection cover and swivel to side. Position heater in ceiling (See Fixing )

A means of disconnection having a contact separation of 3mm in all poles should be incorporated in the power supply

Select power cabling of appropriate size for current and volt drop for the heater.

Select control cabling with 4 cores and earth of appropriate size for current and volt drop

(Control/motor circuit power consumption approx 50W per unit)

Pass cable/s through cord grip in top of unit. Leave sufficient length for connection but ensuring cables do not foul blower unit. Make off connections to connector block and earth stud in accordance with circuit diagram

RCH-W-012 (copy on back page and on top of unit )

Tighten up cord grip. Replace connection cover plate and ceiling tile.

**IMPORTANT : always check to ensure the heating elements cannot be energised without the fan running.**

**WARNING THIS HEATER MUST BE EARTHED**

## OVER TEMPERATURE CUT OUT

Should the heater exceed normal operating temperature the over temperature cut out on the heating elements will operate. The fan will continue to run.

**To RESET** - switch off power to the unit and allow to cool before switching on again. If the problem persists consult a suitably qualified person.

---



---

## FIXING

### RGHS-3210-TT

This unit is designed for installation in a standard 600mm x 600mm modular ceiling. The front cover can be reduced to a minimum 600mm x 400mm for non standard tiles.

The unit weighs 9kgs. and as such can be mounted directly in a correctly installed modular ceiling. As an added precaution additional ceiling supports can be added adjacent to the heater. If the strength of the ceiling is suspect or for a non standard ceiling system additional fixings can be made to the body of the heater by removing the front cover. Ensure fixings are clear of moving parts and cables.

The mounting clips provided allow mounting flush with the ceiling or can be rotated to allow mounting above the T bar. The latter allows the installation of the egg crate grille.

The minimum height between structural ceiling and top of the T bar is 230mm. If there is limited clearance between the structural and suspended ceilings the unit should be inserted through the mounting hole prior to fitting the clips.

Remove 4 clips and 4 machine screws from packing. Fix clips, with machine screws provided, to screwed inserts in side of unit. Position them as required and tighten up screws. Place unit in ceiling ensuring clips engage securely with top of T bar (see dia 1) or flange (see dia 2)

If access and space is available above the suspended ceiling the grille can be put into position first and the heater positioned over it. If space is limited the heater should be positioned first and then the grille inserted by lifting the heater and sliding the grille in from the side.

### RCHR-3210-TT

This unit is designed for installation in a plasterboard or similar ceiling where a free height above the surface of the ceiling is at least 230mm.

A 600mm x 410mm hole should be made in the ceiling and suitably framed.

The unit can be fixed in two ways;

either 1) Remove the front cover of the unit and screw fix through the sides of the unit into the ceiling frame. Replace front cover ensuring all screws are tight and the two shakeproof washers are used.

or 2) Fix clips, with machine screws provided, to screwed inserts in side of unit. Position them as required and tighten up screws. Place unit in ceiling and secure clips to ceiling with woodscrews provided. (see dia 3)

The framed grille is then positioned and fixed by the 6 round headed screws provided.

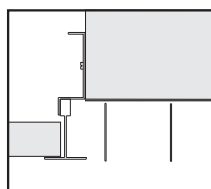

dia.1

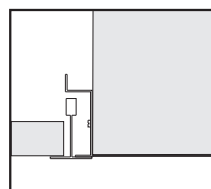

dia.2

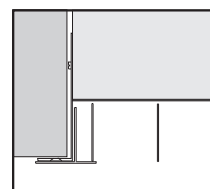

dia.3

## MAINTENANCE

Isolate the heater and remove any build up of dust etc. every 6 months. Check that the heater has not been covered or the airflow restricted in any way.

## WARRANTY

This product is guaranteed, in accordance with our Conditions of Sale, for a period of 12 months from date of purchase. We will repair or replace, at our discretion, any part found to be defective. We cannot accept responsibility for any consequential liability.

The warranty will be invalid if the heater has not been installed in accordance with these instructions. This does not affect your statutory rights.

The manufacturers reserve the right to change the specification at any time without prior notice EO&E

---

Warning  
Multiple supply isolate ALL before opening connection cover.

Relay coil 1(T1T2) to be energised by 230V from timer on/off controlled and fused supply  
Relay coil 2(T3T4) to be energised by 230V from thermostat controlled and fused supply

Heating element incorporates over temperature cut out .  
Fan continues to run if cut out operates.

To reset:  
Switch off and allow to cool (5 minutes) then restore supply

Heater does not function again until power has been removed from cut out.

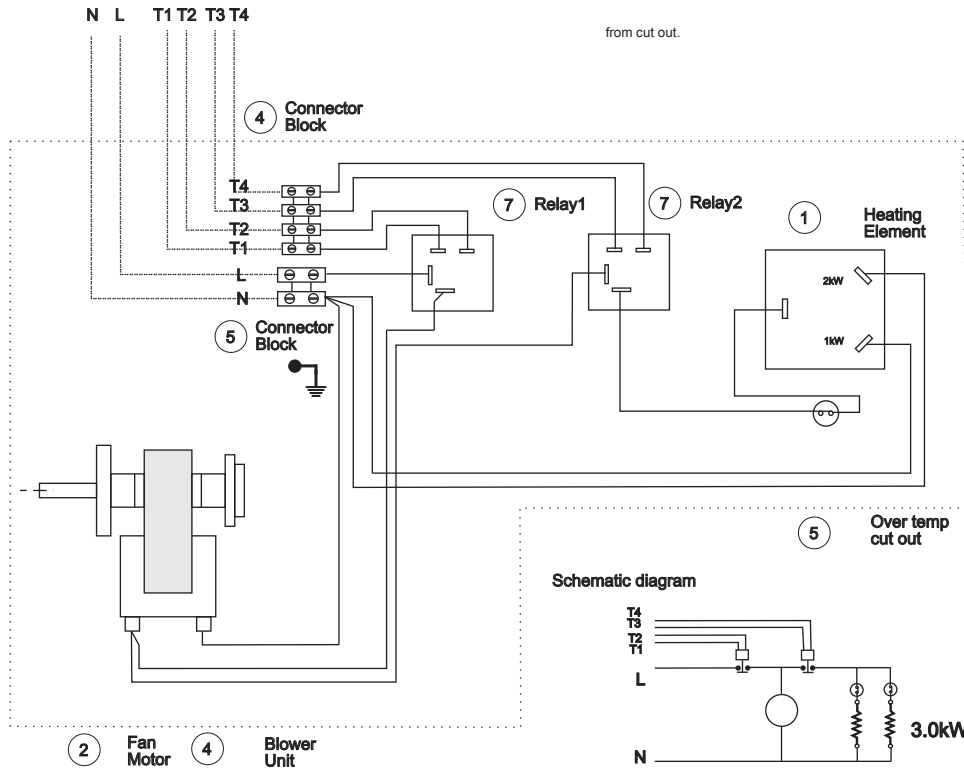

Commercial Electric Heat Limited  
HAWICK TD9 8SL

No	Part No	Description
1	B081-01	Heating element
2	D001-01	Fan motor
3	C001	Blower unit
4	F003	16A Con block
5	F040	40A Con block
6		Over temp cut outs
7	E128	Relay

No	Revision	Date
1	Change relays	01/11
2		

Title **RCHS/R/B-3210-TT**  
**Recessed Ceiling Htr**  
**with integral relays**

Drawn by **NEB** Date **30.08.07**

Scale **nts** Drawing No. **RCH-W-012** Rev **1**

L011

One relay is connected in the incoming live to control the on and off of the heater. A second relay is connected between the first relay and the elements to control the heating elements only.

The fan motor will run continuously when there is power to the heater through relay 1

Each relay is independently switched via a fused power supply controlled by time clock or thermostat

See RCH-W-012 and RCH-W-013 for heater circuit detail

Note: Multiple supply isolate ALL before opening connection cover.

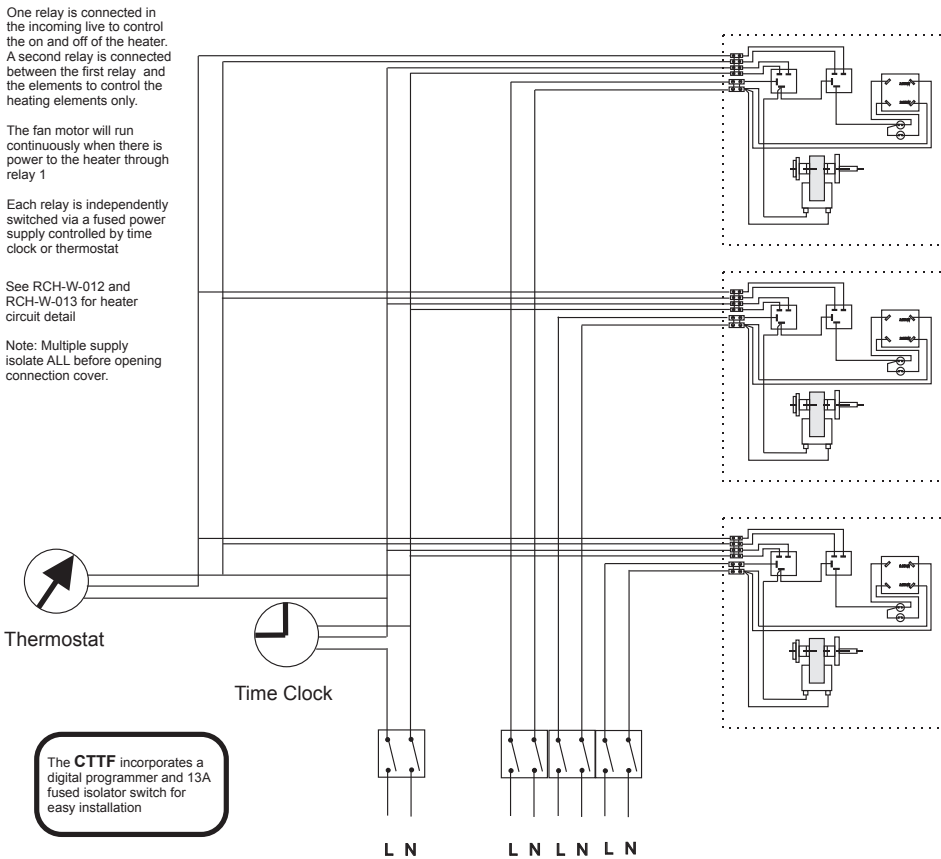

Commercial Electric Heat Limited  
HAWICK TD9 8SL

No	Part No	Description
1		
2		
3		
4		
5		
6		
7		

No	Revision	Date
1		
2		

Title **Typical site connection**  
**RCHX-xxxx TT**  
**Recessed Ceiling Htr**

Drawn by **NEB** Date **30.08.07**

Scale **nts** Drawing No. **RCH-W-014** Rev **0**

L011