

Installation Instructions

The RCHB 3210 Ceiling heater for surface mounting

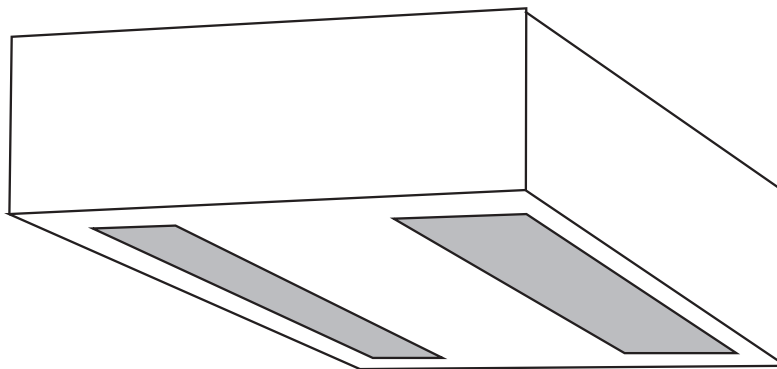

Complete with **REMOTE SWITCH UNIT**
for Fan only, 3, 2 and 1kW

Please retain for future reference



Commercial Electric Heat Limited
Burnfoot Industrial Estate
HAWICK
Roxburghshire
TD9 8SL

Tel 01450 372103 Fax 01450 377800
Email sales@ceh ltd.co.uk Web www.ceh ltd.co.uk

SAFETY

The correct procedures for working at height must be adopted when installing this heater.

The heater must be installed by a suitably qualified person in accordance with current regulations.

CONTENTS

Remove from carton and check contents ;

- heater unit
- RCH-RSW three switch control unit

LOCATION

The heater must be installed at a minimum of 2 m and a maximum of 3m from the floor.

The heater can be positioned in the corner of a ceiling but for better heat distribution at least 600mm from each wall is preferable.

The unit should not be positioned over desks, counters or high level display racking wherever a constant flow of heated air may be uncomfortable or cause overheating of equipment.

CONTROL

Remote Switch

The Remote Switching Unit allows ON/OFF, Fan only with 1,2 or 3 kW.

Thermostat (CRST16)

A thermostat of 16A rating can be connected in the power supply to the Remote switch thus switching the unit off totally when set temperature is reached. Alternatively a thermostat and contactor can be used.

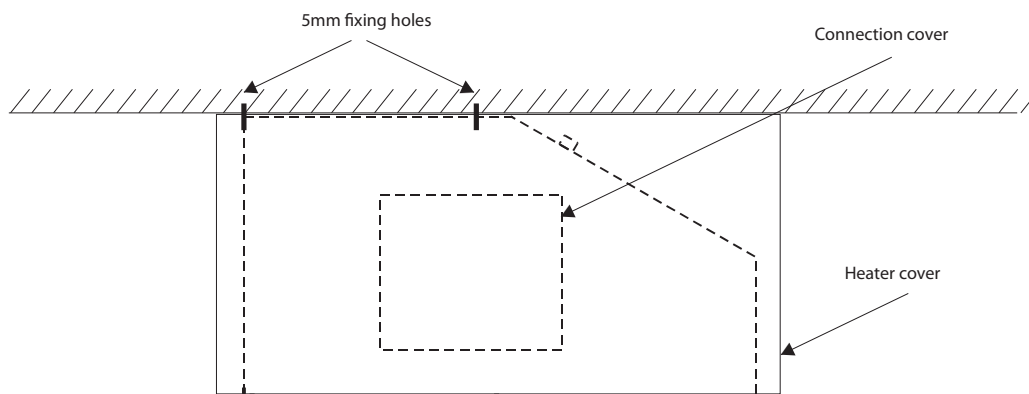

FIXING

This heater is designed for surface installation to any ceiling that can adequately support the unit. The unit weighs 9kgs.

Remove the front cover of the unit

Fixings are made through the top flat section of the heater body using the 4 No 5mm holes provided. This section must be flat on the ceiling as the edges of the cover are designed to fit against the ceiling.

Securely fix the heater and make off the electrical connections taking into account the routing of cables in relation to the cover. Ensure fixings and cables are clear of moving parts and the heater elements.

Re fix the cover ensuring the fan outlet is adjacent to the smaller outlet grille.

ELECTRICAL CONNECTION

The heater should be installed in accordance with the latest edition of the IEE Requirements for Electrical Installation (BS 7671:2001)

Position heater on ceiling (See Fixing)

Remove side connection cover (2 set screws)

Position remote switch unit in suitable location.

A means of disconnection having a contact separation of 3mm in all poles should be incorporated.

Select cabling with 4 cores and earth of appropriate size for current and volt drop.

Pass cable/s through cord grip in top of unit. Leave sufficient length for connection but ensuring cables do not foul blower unit. Make off connections to connector block and earth stud in accordance with circuit diagram RCH-W-007 (copy on back page and on top of unit)

If remote switching is not required connect power supply to L and N and link L,LI and LII with 1.5sqmm cable.

Tighten up cord grip. Replace connection cover plate. Replace heater cover.

IMPORTANT : always check to ensure the heating elements cannot be energised without the fan running.

WARNING THE HEATER MUST BE EARTHED

OVER TEMPERATURE CUT OUT

Should the heater exceed normal operating temperature the over temperature cut out on the heating elements will operate.

To RESET - switch off power to the unit and allow to cool before switching on again. If the problem persists consult a suitably qualified person.

MAINTENANCE

Isolate the heater and remove any build up of dust etc. every 6 months. Check that the heater has not been covered or the airflow restricted in any way.

WARRANTY

This product is guaranteed, in accordance with our Conditions of Sale, for a period of 12 months from date of purchase. We will repair or replace, at our discretion, any part found to be defective. We cannot accept responsibility for any consequential liability.

The warranty will be invalid if the heater has not been installed in accordance with these instructions. This does not affect your statutory rights.

The manufacturers reserve the right to change the specification at any time without prior notice EO&E



Commercial Electric Heat Limited
HAWICK TD9 5SL

No	Part No	Description
1	B081-01	Heating element
2	D001-01	Fan motor
3	F003	Connector block
4	C001	Blower unit
5		Over temp cut out
6	RCH-RSW	Remote Sw Unit

6

Remote Switch RCH-RSW

IMPORTANT:
Any modification to the switching in this circuit must ensure that the heating elements cannot be energised without the fan running.

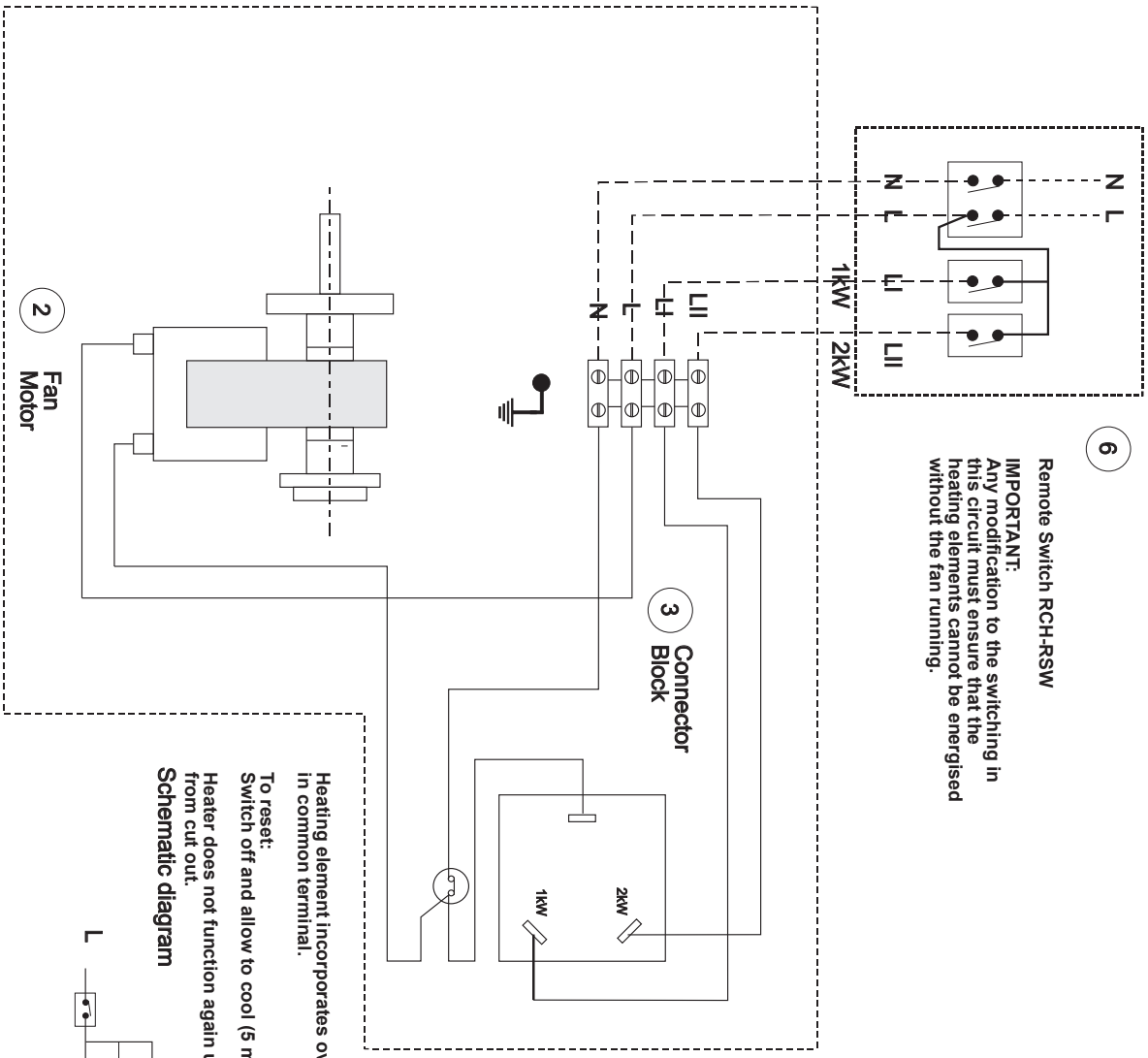

3 Connector

1 Heating Element

4 Blower Unit

5 Over temp cut out

Heating element incorporates over temperature cut out in common terminal.

To reset:
Switch off and allow to cool (5 minutes) then restore supply
Heater does not function again until power has been removed from cut out.

Schematic diagram

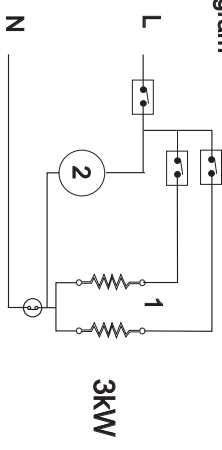

No	Revision	Date
1	add external cut out	11/04
Title		
RCHS/R 3210		
Recessed Ceiling Htr		
Drawn by		
NEB		Date
		10.06.98
Scale		
Drawing No.		Rev
RCH-W-007		1

L011