

Installation Instructions

CWD Recessed Fan Heater (110V)

Reference
J401b

Remove from carton and check contents :-

- grille and fixing screws (2)
- heater assembly and fixing screws (2)
- recess box CWD-R

CAUTION

DO NOT use in areas where an AVERAGE temperature of 5 deg.C or less is to be maintained.
DO NOT mount beneath towel rails or behind doors or in any way obstruct the heater airflow.

HEATER LOCATION

The heaters are designed for recessed or surface mounting. They may be wall mounted in a vertical position for top discharge only or horizontal position with right or left discharge.

The minimum clearance from wall box to adjacent wall or floor is 150mm.

The heater must be mounted in the wall box supplied.

When RECESSED the front edges of the wall box MUST be level with the finished surface of the wall .

RECESSED MOUNTING

- 1) Create cut-out 370mm x 182mm in wall ensuring adequate fixing locations are available. The recess must be at least 90mm deep with adequate access for cabling. The wall box must be fixed on at least one edge with the front edge flush with the finished wall surface.
- 2) Remove appropriate knock out and fix recess box. Pull through sufficient cable to make connections.
- 3) Make connections to terminal block and earth screw.
- 4) Install heater assembly into recess box. Secure heater in box with four screws provided.
- 5) Assemble grille to heater fixing with two screws provided.
- 6) If thermostat is fitted remove hole plug from grille. Align flat of thermostat shaft with flat of knob and push knob onto shaft until it almost touches grille.
- 7) For tamper proof operation, set thermostat with knob, remove knob and replace hole plug. Retain knob for future use.

SURFACE MOUNTING

- 1) Securely fix recess box to wall via fixing holes in back.
- 2) Proceed as for recessed fixing (2 - 4).
- 3) Position surface box over unit and fix grille with screws provided clamping box between wall and grille.
- 4) Fit thermostat knob if specified.

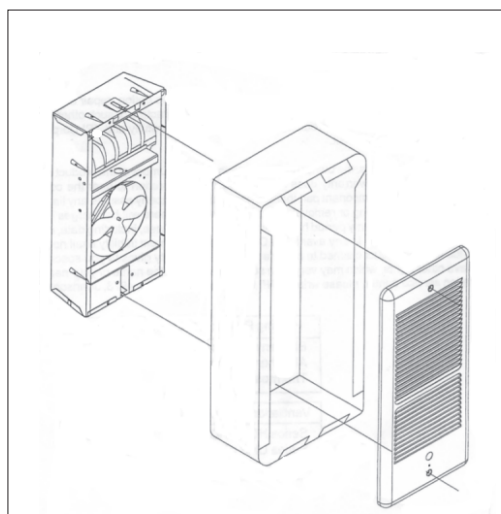

ELECTRICAL CONNECTIONS.

The heater should be installed in accordance with the latest edition of the Requirements for Electrical Installations (BS7671:2001) by a suitably qualified person.
 The unit should be permanently connected to a suitable 230Vac 50Hz power supply incorporating a means of isolation having a contact separation of at least 3mm in all poles:-

WARNING: THE HEATER MUST BE EARTHED.

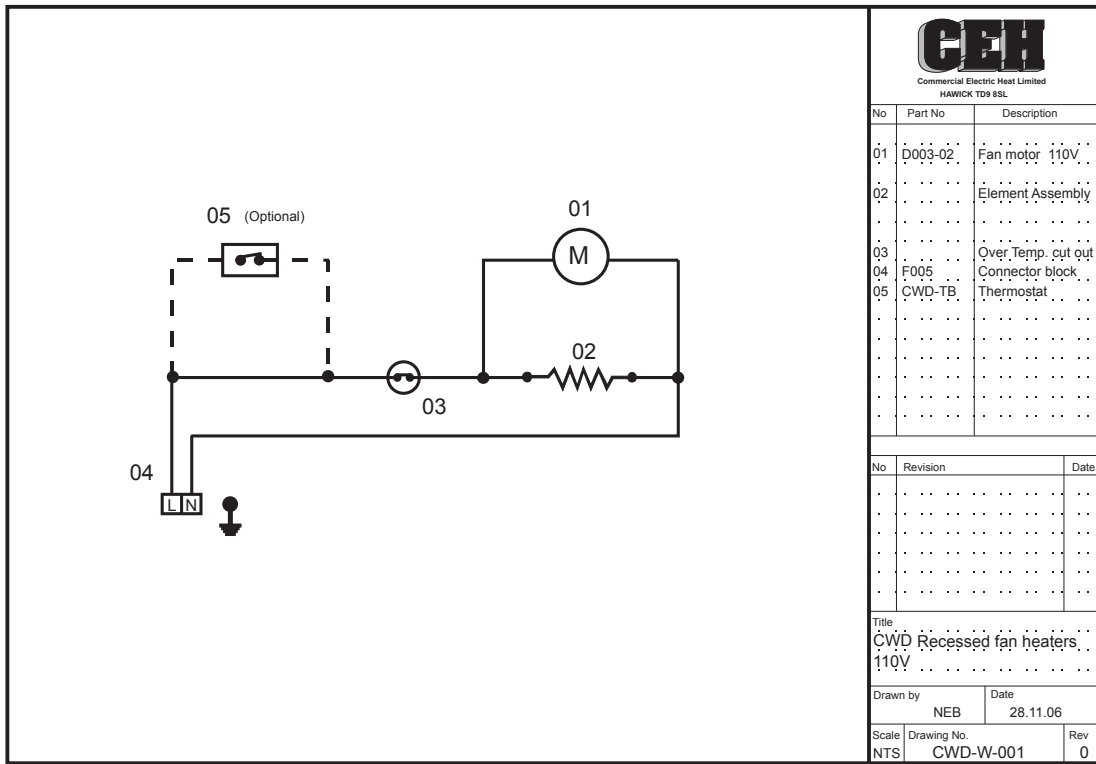

OVER TEMPERATURE CUT OUT

This heater is fitted with a manual reset over temperature safety cut out designed to open if excessive high temperatures occur. If it opens the heater and fan will cease to operate.

The cut out is located centrally between the fan and elements.

To reset: -

- 1) Disconnect power
- 2) Insert small blade screwdriver through grille and push in small red button.

THERMOSTAT OPERATION (if fitted)

Turn thermostat fully clockwise. Allow heater to run until room is at desired temperature.

NOTE: Heater must run for approx. 5 minutes before thermostat will control at desired comfort level.
 Turn thermostat counterclockwise until heater just turns off.

CLEANING

The heater should be cleaned occasionally to reduce the build up of dust which may cause the unit to overheat.

WARRANTY

This product is guaranteed, in accordance with our Conditions of Sale, for a period of 12 months from date of purchase. We will repair or replace, at our discretion, any part found to be defective. We cannot accept responsibility for any consequential liability.

The warranty will be invalid if the heater has not been installed in accordance with these instructions. This does not affect your statutory rights.

Please keep these instructions for future reference.

The manufacturers reserve the right to change the specification at any time without prior notice E&OE

N11



Commercial Electric Heat Limited
 Burnfoot Industrial Estate
 HAWICK
 Roxburghshire
 TD9 8SL

Tel 01450 372103 Fax 01450 377800
 Email sales@cehltd.co.uk Web www.cehltd.co.uk