

Installation Instructions CQIR Quartz Infra-red Heater

Reference
J270f

SAFETY

The correct procedures for working at height must be adopted when installing this heater.

The heater must be installed by a suitably qualified person in accordance with current regulations.

CONTENTS.

Remove from carton and check contents:

- heater unit with lamp packed within unit
- mounting bracket (2 pieces)
- 2 no. Threaded knobs 1 no set screw and nyloc nut.

Ensure all packing material is removed and grilles are clear.

ASSEMBLY

- 1) Remove front wire guard by removing 4 no screws.
- 2) Carefully remove lamp packed within the unit.
- 3) Remove plate on back of the unit to gain access to the connections.
- 4) Partially remove wrapping from lamp to release connecting cables.

Do NOT directly handle the lamp - use the wrapping material or tissue.

- 5) Thread the connecting cables through slots at either end of the lampholder and clip lamp into spring mountings. Ensure cables are not snagged and clips are engaged.
- 6) Replace front wire guard.
- 7) Fix lamp push on connectors to L and N terminals on connector block.

NOTE. Touching the lamp with bare fingers can damage the quartz tubing and cause premature failure. Any fingerprints must be removed with methylated spirit prior to switch on.

LOCATION.

This heater is designed for high level use. It must not be installed less than 1.8 metres from floor level. It should not be positioned immediately below a fixed socket outlet or any equipment that may be affected by heat.

Minimum distances to adjacent surfaces must be adhered to - see diagram

Care should be taken to ensure that flammable materials are not under the direct influence of the heater and that they cannot be placed near the unit at any time ie relocation of movable storage units etc. This could present a fire risk.

Mounting height and positioning is determined by the heating design.

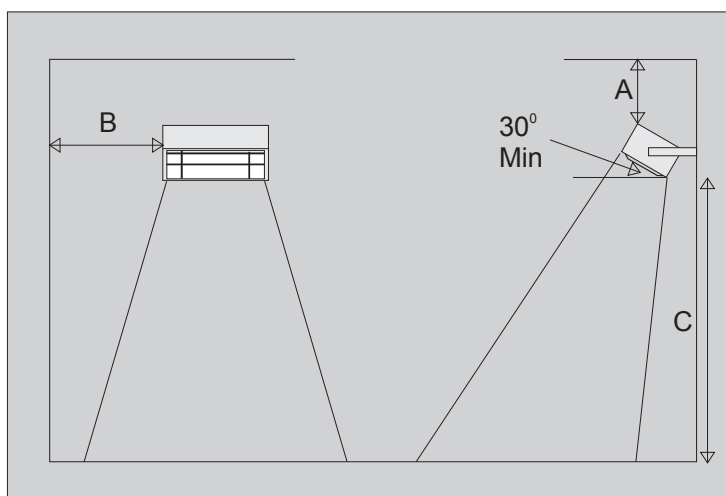

	Minimum distance		
	A m	B m	C m
1500	300	300	1800
2000	300	300	2500
3000	500	500	3000
4000	500	500	3000
4500	500	500	3000
6000	500	500	4000

FIXING.

The unit must be fixed horizontally or premature failure of the lamp can occur.
The heater must be mounted using the bracket supplied ensuring minimum mounting clearances to the wall and/or ceiling are maintained.

The units can be ceiling mounted but must be at an angle of **at least 30° to the horizontal**

The small bracket is fixed to the wall with the plugs and screws provided. The U bracket is then assembled to it with the set screw and nyloc nut . The threaded knobs should be pre assembled to the heater and then slotted into this bracket, directed as required and the threaded knobs tightened securely .

ELECTRICAL CONNECTIONS.

Electrical connections are made to the terminal block using HEAT RESISTING cable of the appropriate conductor size.

The cable must be fixed within the cord grip,

The unit should be permanently connected to a suitable 230Vac 50Hz. power supply incorporating a means of isolation having a contact separation of at least 3mm in all poles.

Connect as follows:-

Green-yellow wire to terminal marked E , with earth symbol 
Blue wire to terminal marked N
Brown wire to terminal marked L

The heater must be earthed

All Electrical connections should be made by a suitably qualified person in accordance with the latest edition of the IEE Requirements for Electrical Installation (BS 7671:2001)

CONTROLS.

Near instantaneous heat allows easy control of Quartz infra red heaters. Power regulators and proximity detectors can be used for an efficient installation.
Infra red lamps produce a surge of several times rated current for a few hundredths of a second on switch on and consideration must be given for this when sizing all controls.
Circuit breakers able to take the high initial surge should be used.
If an air sensing thermostat is used this must be positioned out of the direct line of heat.

WARRANTY

This product, excluding the heat lamp(s), is guaranteed, in accordance with our Conditions of Sale, for a period of 12 months from date of purchase. We will repair or replace, at our discretion, any part found to be defective. We cannot accept responsibility for any consequential liability.
The warranty will be invalid if the heater has not been installed in accordance with these instructions.
This does not affect your statutory rights.

Please keep these instructions for future reference

The Manufacturers reserve the right to change the specification without prior notice EO&E

P09



Commercial Electric Heat Limited
Burnfoot Industrial Estate
HAWICK
Roxburghshire
TD9 8SL

Tel 01450 372103 Fax 01450 377800
Email sales@cehltd.co.uk Web www.cehltd.co.uk